

# Prestressed steel structures: historical and technological analysis.

A. Masullo

*Marigliano, Napoli, Italy*

V. Nunziata

*Studio Nunziata, Palma Campania, Napoli, Italy*

**ABSTRACT:** This paper deals with the historical development of the technique of prestressing; from prestressed concrete (P.C.) to prestressed steel (P.S.). The latter is described in terms of its realization. In addition, several Italian cases are reviewed, which have adopted this technique and finally some experimental work is presented which shows the advantages that the widespread use of P.S. can bring to the sphere of the construction sector.

## 1 INTRODUCTION

Although seemingly recent, prestressed steel is a material whose origins date back a long way. The adoption of the technique of prestressing is attributed to Paxton, who in 1851, utilized this technique for the realization of Crystal Palace (fig. 1), unaware of the great discovery he had made.



Figure 1. Crystal Palace.

Koenen was the first to propose prestressing steel bars. He suggested doing this in 1907, before applying concrete, in order to avoid the formation of cracks and thus stumbled across the innovation of reinforced concrete (R.C.). Unfortunately however, his attempts failed because at that time the phenomena of flange and shrinkage were unknown. In fact, the real “father” of prestressing is Eugène Freyssinet (fig.2), who in 1928 defined prestressing as a technique which consists in subjecting a material, in his case reinforced concrete, to loads which produce stresses opposed to those in operation, through the use of cables which have first been laid in the stressed mass.

The reasons which gave rise to this material may be found in the mechanical characteristics of concrete which, in fact, shows great ability to absorb forces of compression but a low resistance to tension which is allowed to be absorbed by the metallic reinforcement. The latter, in its turn, under the effect of ten-

sion tends to lengthen and, on account of the phenomenon of bonding, pulls the concrete along with it.



Figure 2. Eugène Freyssinet.

Consequently, if the stresses of tension are high, the concrete will crack. The cracks do not destabilize the structure but could lead to possible further deformation and expose the reinforcement to the danger of oxidization which in turn produces a reduction of its own resistance. It can be deduced that R.C. can tolerate loads up until the cracking limit. Unlike R.C., steel is a material which has high resistance both to tension and to compression. As a consequence, by making a comparison between prestressed steel and reinforced concrete, we can immediately note that in the first place, this technique further raises both the quality and the resistance to tension and compression characteristics of the steel (the technique actually manages to create a state of co-action in which

the tensions and deformations are opposed to those induced by the loads which will subsequently act upon the structure). In the second place however, it raises the resistance to tension of reinforced concrete which is, in fact, negligible.

### 1.1 The technologies.

The technique for realizing prestressed steel is achieved through external cables.

Here too we notice a further difference with reinforced concrete, which employs different techniques for its realization:

- 1 Bond cables (fig. 3), in which the reinforcements are anchored due to bonding between steel and concrete;
- 2 Sliding cables (fig. 4), in which the reinforcements are placed within plastic sheaths, allowing them to slide.

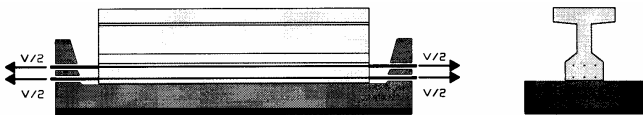

Figure 3. Prestressing with bonding cables



Figure 4. Prestressing with sliding cables.

As has already been stated, a steel beam adopts prestressing with external cables (fig. 5), which foresees the use of a type of steel with elevated mechanical characteristics ( $f_{ptk} = 1800 \text{ N/mm}^2$ ) and which is available on the market in the form of stabilizing seven-thread strands, spiraled around a central thread with a pitch of 12-16 times the diameter. Normal steel of type Fe 430 and Fe510 is used.

This procedure requires a preliminary phase of preparation which include the following operations:

- 1 Preparation of the girder through the insertion of contrast elements to the cable which define the passage along the girder (deflectors);
- 2 Formation of the cable;
- 3 Placing the cables in position and their subsequent anchoring;
- 4 Applying tension to the reinforcements with jacks and tightening them;
- 5 Eventual re-tightening;

All this must be done with maximum care and requires a specialized workforce.

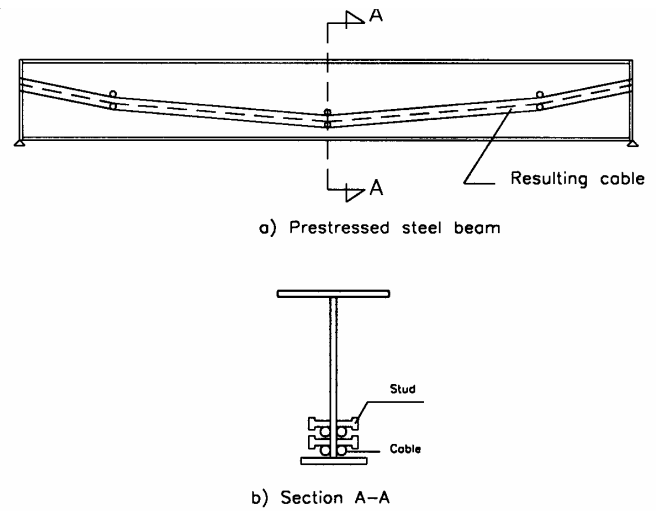

Figure 5. Technique of prestressing with external cables.

The first operation to carry out is to single out the line of the resulting cable and then to position the contrasts, made up of symmetrical studs which define the line of the cables themselves whose barycentric line is known as the "resulting cable". Technically, the contrasts are realized through symmetrical studs with regard to the web of the girder. The studs are capped at one end to keep the cable in position and are welded to the web. Their number depends on the length of the girder and the stresses in play (fig.6).

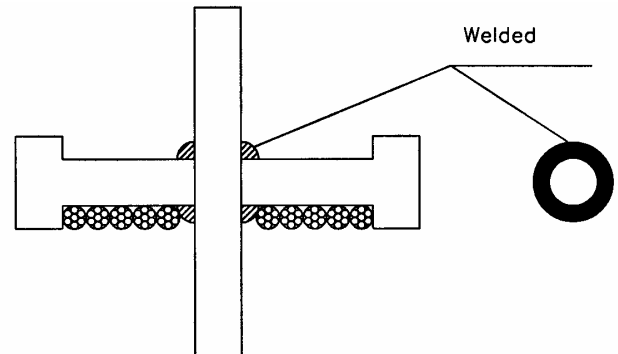

Figure 6. Details of the deflector stud.

Once this operation is completed, the next stage is the formation of the cables. During this operation the strands are laid symmetrically in relation to the web and are freely left to run around the deflectors which have been greased or lubricated to avoid friction. The strand, which is made of high tensile steel is more susceptible by nature to corrosion than normal steel and is therefore protected against this risk. The protection is done through zinc-plating (galvanized strand) or through sheathing (sheathed strand) which consists in placing the strand (often zinc-plated) in a high density polyethylene sheath in which it can slide freely due to the presence of grease or wax which also act as protection against corrosion. With this technique it is also possible to replace strands which turn out to be unsuitable. Protection against

corrosion can also be obtained by using a sheath of HDPE into which the strands are inserted. The sheath will subsequently be injected with cement paste as occurs with reinforced concrete.

The next phase is anchoring which is the most delicate phase of the entire operation. A very simple system of anchoring is shown in figure 7. It is made up of :

- A rigid plate
- blockings
- steel stiffeners.

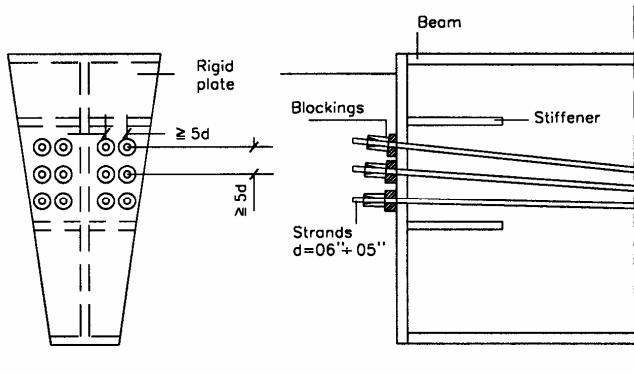

Figure 7. System of anchoring.

In particular, anchoring the strands foresees the use of conical-trunk ferrules inside of which are toothed wedges of the same shape that hold the steel before tensioning (fig.8). Indeed, tightening is assured precisely because of the contact between the strand and the wedge since the strand, tending to pull in on itself, drags the wedge with it and thus self-blocks.

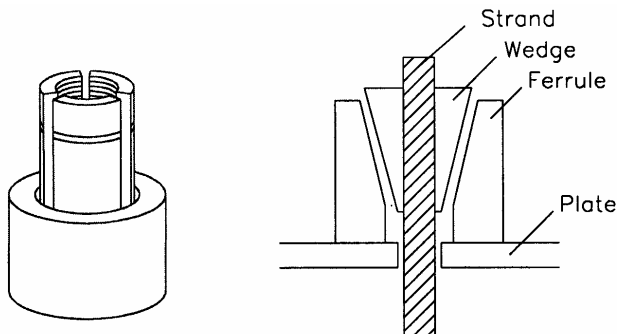

Figure 8. Ferrule for anchoring strands.

After the preparation phase, the next step is to determine the action acting upon the girder, as well as those associated with those induced by prestressing.

It must be added that the sections most adapted to prestressing are those boxed beams (fig. 9) and those with a plate girder ( a di-symmetrical double T) (fig. 10) since these are the ones that most suit this technique, allowing for maximum exploitation of the material.

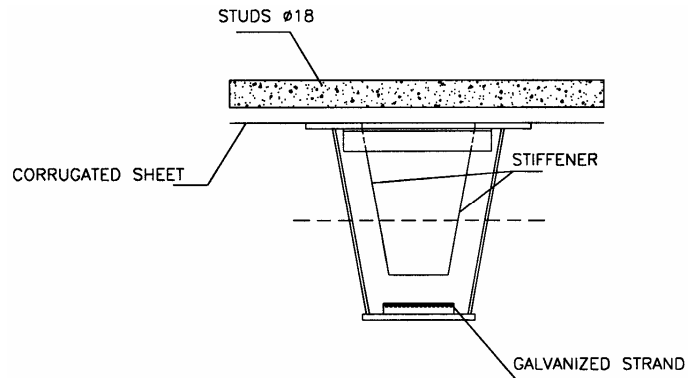

Figure 9. Box girder

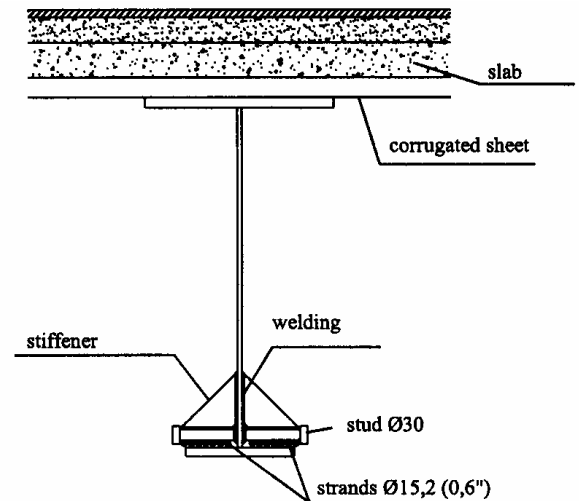

Figure 10. Di-symmetrical double T girder.

## 2 THE REALIZATIONS.

Even though structures in P.S. offer many advantages, both economically and technically, unfortunately, at least in Italy, their use has been limited to a very few cases.

Recently in Rome, two roof covers have been constructed, belonging to two different typologies: a commercial center and a multiplex.

The first is the Gulliver commercial center (fig.11). Here, a flat roof cover has been realized with the use of prestressed reticular girders of 21.90 meters, centered apart at 3.00 meters. A slab of concrete on predalles was cast between them. Prestressing was carried out with eight 15mm diameter strands, raised linearly towards the supports. Protection of the strands was achieved with a controlled jet of mortar that fills the U-profile in which they were lodged. The girders were constructed in two parts and put together with bolts and pre-tensioning of the strands. The second roof cover was realized for the Lucchina multiplex (fig.12).



Figure 11. Detail of the roof cover of the Gulliver commercial center.

In its construction, 17.20-meter transversal girders were used. These were centered apart at 3.60 meters and laid on main girders which were supported on columns of concrete. Between these and the secondary girders, corrugated sheets were positioned onto which a collaboration slab of reinforced concrete was cast. Prestressing of the transversal girders was done in a workshop using four 15mm waxed-type strands and then mounted with bolted joints.



Figure 12. View of the roof cover of the La Lucchina multiplex.

## 2.1 Experimentation

Having described the techniques for employing prestressed steel and described two of the works carried out in Rome, it would be useful to present the results of an experiment which started in April '99 under the guidance of the engineer, Mr Nunziata. The test consisted in observing and studying the behavior of a 21.40-meter pre stressed steel girder.

It goes without saying that the girder had first been studied theoretically to determine its dimensions, loads and other characteristics, after which it was realized. The girder is shown in figure 13.



Figure 13. View of the girder.

The girder has the following characteristics:

It has a height of 80 cm., and is prestressed with ten strands, foreseeing a total capacity of 21,6 kN/m, (equal to 10,2 kN/m for dead loads and 11,4 kN/m for imposed loads) excluding its own weight which is equal to 1,72 kN/m. The beam was positioned in an outdoor courtyard and rested on two supports, one of which was a sliding bearing and the other a hinge (fig.14).



Figure 14. Sliding bearing

The strand deflectors were positioned, which in turn, were anchored at the ends of the girder with blockings (fig.15). Finally, we proceeded to the distribution of the load with blocks of cement of 25 kN (fig.16) and to the tightening of each strand with a force of an intensity equal to 151 kN.



Figure 15. Anchoring the ends.



Figure 16. Distribution of load.

After this, we passed to the measurement of the deflection in the middle span with a fiftieths caliber for the three fundamental phases (fig.17). The following results were obtained:

- 1 In the at transfer phase, the deflection is equal to 54.54 mm.
- 2 In the loading phase, taking into account the climatic conditions, the following values were recorded:
  - -68.32 mm. immediately after loading phase;
  - -76.04 mm. after three days;
  - -76.00 mm. after one week;
  - -77.80 mm. after twelve days;
  - -78.70 mm. after thirteen days;
  - -79.84 mm. after about a month;
  - -79.64 mm. after over two months.
- 3 In the unloading phase, we recorded an elastic return and the final deflection was 37.84 mm.

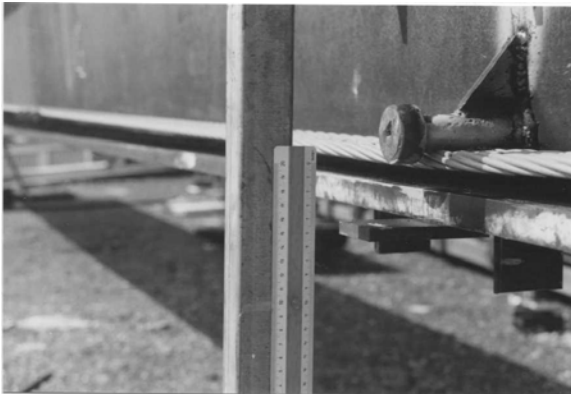

a) Initial



b) Loaded

Figure 17. a) measurement of the deflection at transfer phase; b) measurement of the deflection at loading phase.

Through this experiment, even though it was carried out under difficult conditions, the results obtained were significant and underline two particular facts:

- 1 The superiority in terms of resistance and deformation of structures in prestressed steel compared to analogous structural typologies;
- 2 The economy and simplicity of execution of the proposed technology which can be realized with simple elements and is accessible to all.

### 3 CONCLUSIONS

Although this paper presented information in a very concise manner, it has illustrated some structures in prestressed steel and a technology which is very simple. This is in the hope that such a technique will become more widely used since prestressed steel is a material which can bring both economic benefit (since the realization of a girder in P.S. brings a savings of 15% compared to a normal one) and technical benefit (being a lightweight material that has great resistance) to the sphere of the construction industry.

### 4. BIBLIOGRAPHY.

Nunziata, Vincenzo 1999. *Strutture in acciaio precompresso*. Palermo: Dario Flaccovio, Editore.