

# Prestressed steel structures design: a new frontier for structural engineering

V. Nunziata

Studio Nunziata, Palma Campania, Napoli, Italy

**ABSTRACT:** In this paper we introduce the theoretical principles and illustrate the calculation methods when dealing with prestressed steel beams. Our aim is to make this structural typology more *widely known* and to furnish simple *calculation methods*, which in our opinion, are the real obstacle to the development of this particular structural type. Furthermore, the use of prestressed steel, compared to other typologies, offers otherwise unattainable economic and technological advantages.

## 1 INTRODUCTION .

The main reasons why prestressed steel structures are infrequently erected is due, in our opinion, to a lack of knowledge regarding the *system* and the *calculation methods*. Once this information becomes general knowledge within the scientific and the construction community, there will be the same rapid adoption of prestressed steel (P.S.) technology as there was for similar technologies, for example, prestressed concrete (P.C.). In this respect, prestressed steel technology is the new frontier for structural engineering. The aim of this paper is to present a static analysis of significant prestressed steel structures, together with relevant results, and to compare them with other structural typologies.

## 2 ANALYSIS OF PRESTRESSED STEEL STRUCTURES

### 2.1 General

A prestressed system consists quite simply in “subjecting a structure to loads that produce opposing stresses to those when it is in service”. Prestressing can be usefully applied to any material and, in particular to steel (figure1), thus improving considerably its resistance characteristics.

In the case of P.C., the effect of prestressing enables beams to pass from being partial reagents to becoming total reagents (only compression), (figure 2). The increase in the characteristics of resistance are solely due to a greater use of the section. In the case of steel this is taken for granted.

The methods used for analyzing the sections are:

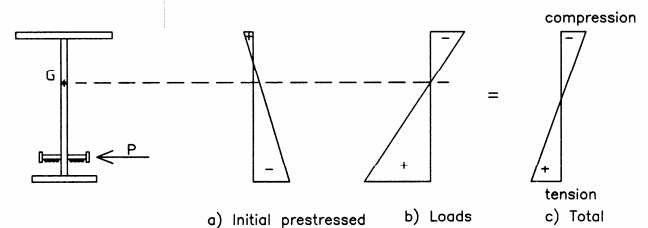

Figure 1. Prestressed steel girder: principle of function.

*The static method*, which in each section considers the effect of prestressing as an eccentric pressure (traditional method).

*The equivalent loads method*, in which the effect of prestressing is analyzed through the introduction of a system of equivalent forces of external provenance which exert pressure upon the girder and are called “equivalent loads”.

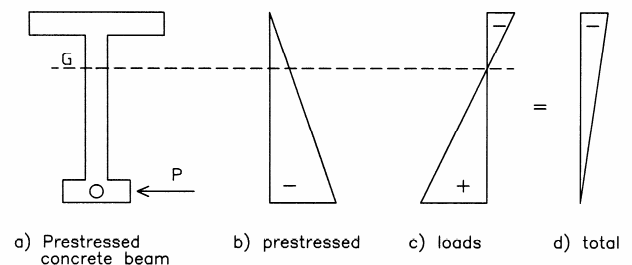

Figure 2. Prestressed concrete beam: principle of function.

### 2.2 Static analysis of the section

With reference to a simply supported prestressed steel beam, it will be necessary to assess whether in the section most under stress, the tensions owing to the loads and the prestressing are lower than those

allowed for by the limit state under consideration. An admissible value for *tension loss* for P.S., on account of *friction* and *steel relaxation* is 5%. The value we take into consideration is 10% (generally for P.C., *tension losses* due to friction, creep shrinkage etc are presumed to be 25% - 30%). Two load conditions will be taken into account, more precisely, an initial or “at transfer” condition and a final or “at service” condition. In the first case the prestressing force  $P$  will be increased through the application of a co-efficient  $\beta = 1.10$  to take account of the total (or final) tension loss.

### 2.2.1 Bending.

It may be said that prestressing was invented for bending girders and it is for this state of stressing that we gain the most benefits.

In reference to figure 3, it may be verified, at transfer:

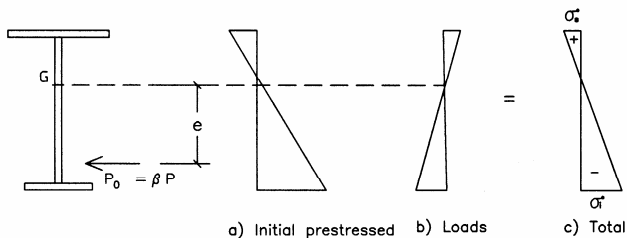

Figure 3. Condition at transfer.

$$\sigma_i^0 = -\frac{\gamma_p \beta P}{A} - \frac{\gamma_p \beta P e}{W_i} + \frac{M_{\min}}{W_i} \leq f_d$$

where:  $A$  and  $W_i$  are respectively the area and the lower resistant modulus of the steel girder,  $\gamma_p$  is the partial coefficient of safety applied to the prestressing,  $M_{\min}$  is the minimum moment calculated, taking into account the partial coefficients of safety applied to the loads,  $e$  is the distance of the resulting cable from the barycentre  $G$ .

Placing an equals sign between the stresses we will obtain  $P$  for which verification at transfer is no longer necessary, or rather:

$$\sigma_i^0 = f_d \Rightarrow P$$

At service, figure 4, will verify:

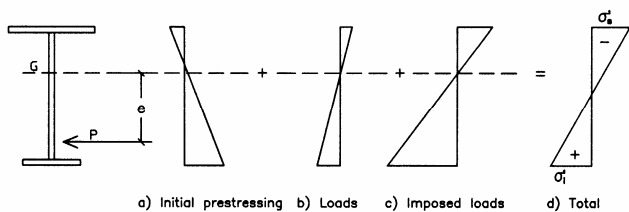

Figure 4. Condition at service.

$$\begin{cases} \sigma_s^1 = -\frac{\gamma_p P}{A} + \frac{\gamma_p P e}{W_s} - \frac{M_{\max}}{W_s} \leq f_d \\ \sigma_i^1 = -\frac{\gamma_p P}{A} - \frac{\gamma_p P e}{W_i} + \frac{M_{\max}}{W_i} \leq f_d \end{cases}$$

where:  $W_s$  is the higher resistant modulus of the steel girder,  $M_{\max}$  is the maximum moment taking into consideration the partial safety coefficients applied to the loads.

The intervention of an external moment causes the prestressing force (or rather, the center of pressure) to shift :

$$\delta_0 = \frac{M_{\min}}{\beta \cdot P^*} \quad \delta_1 = \frac{M_{\max}}{P^*} \quad \text{where: } P^* = \gamma_p \cdot P$$

This allows us to make a useful, though qualitative, analysis of the prestressing of steel girders and to highlight the main differences and limitations of prestressed concrete. In figure 5, given  $e_i$  and  $e_s$  the distances of the lower and higher kern points from the barycentre point,  $d$  the distance of the resulting cable from the lower kern point, we may see that the prestressing force shifts from point  $K_0$

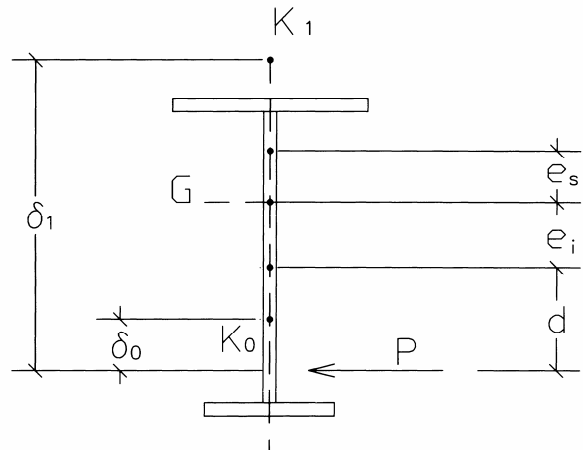

Figure 5. Representations of kern points  $e_i$  and  $e_s$

to point  $K_1$  during the passage from the at transfer phase to the at service phase. The two points are both external to the central kern area (the section is partly compressed and partly under tension). The useful moment ( $M_u$ ) in which the section will be able to absorb is :

$$M_u = M_{\max} - M_{\min} = P^* \delta_1 - \beta P^* \delta_0;$$

$$M_u = P^* (\delta_1 - \beta \delta_0) = P^* K_a$$

$$\text{having placed } K_a = (\delta_1 - \beta \delta_0).$$

For P.C., we generally ignore its slight traction resistance and the section is proportioned in such a way as to obtain (fig. 6):

$$\sigma_s^0 = 0; \quad \sigma_i^1 = 0$$

which causes the prestressing force to shift in the lower kern point, at transfer, and in the higher kern point at service. In this case we obtain :

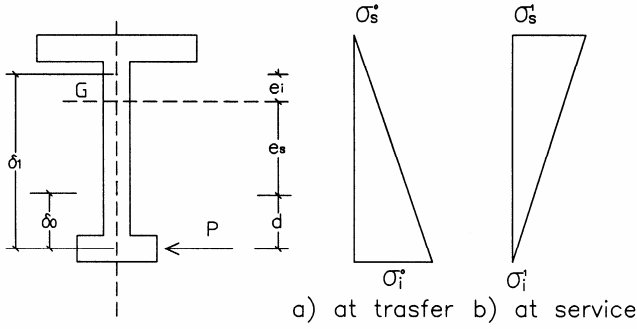

Figure 6. Prestressed concrete girder.

$$M_u = P^* (\delta_1 - \beta\delta_0) = P^* [(d + e_s + e_i) - \beta d] = P^* K_c$$

having placed  $K_c = [(d + e_s + e_i) - \beta d]$ .

The first observation that may be made on the basis of the preceding results is that in prestressed steel, the limits between which the prestressing force  $P$  shifts are wider. The second observation is that a prestressed concrete girder will have to remain compressed throughout its entire working life which constitutes a significant limitation given the extreme variety of imposed loads and the possibility that a situation could occur that was not foreseen at the design stage.

### 2.2.1.1 Cable zone (or Guyon zone)

We propose to determine the zone within which the plot of the resulting cable must be anticipated without going beyond the limits considered in any section of the girder. The primary operation is to ascertain the two characteristic points of the section (or limit points)  $E_0$  and  $E_1$ , figure 7, corresponding to the maximum deviation that the center of pressure may tolerate at transfer and at service, without exceeding the limit state considered.

In the at transfer phase, given  $e_0$  the deviation from the center of pressure, we have:

$$\sigma_i^0 = -\frac{\beta P^*}{A} - \frac{\beta P^* e_0}{W_i} \leq f_d$$

the satisfying of the inequality, in the form of equality, permits us to find  $e_0$ , or rather:

$$\sigma_i^0 = f_d \Rightarrow e_0 = -\frac{\rho^2}{y_i} \left(1 - \frac{f_d}{\sigma_m^0}\right)$$

where:

$$\rho^2 = \frac{I}{A}; \quad \rho_m^2 = \frac{\beta \cdot P^*}{A};$$

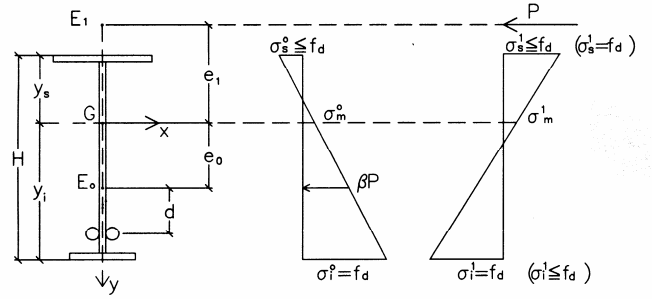

Figure 7. Limit points.

In the at service phase, given  $e_1$  the deviation of the point of pressure, we have :

$$\begin{cases} \sigma_i^1 = -\frac{P^*}{A} + \frac{P^* e_1}{W_i} \leq f_d \\ \sigma_s^1 = -\frac{P^*}{A} - \frac{P^* e_1}{W_s} \leq f_d \end{cases}$$

the satisfying of the two inequalities, in the form of equality, allows us to find two values of  $e_1$  the lesser of which in absolute value, will represent the higher limit point. From:

$$\sigma_i^1 = f_d ; \quad \sigma_s^1 = f_d ;$$

we obtain:

$$\begin{cases} e_1' = +\frac{\rho^2}{y_i} \left(1 + \frac{f_d}{\sigma_m^1}\right) \\ e_1'' = -\frac{\rho^2}{y_s} \left(1 - \frac{f_d}{\sigma_m^1}\right) \end{cases} \Rightarrow \begin{cases} e_1 = e_1' \text{ se } |e_1'| < |e_1''| \\ e_1 = e_1'' \text{ se } |e_1''| < |e_1'| \end{cases}$$

In order to verify the section we will have to check it respectively at transfer and at service:

$$\begin{cases} M_{\min} \geq \beta P^* d \\ M_{\max} \leq P^* (d + e_0 + e_1) \end{cases}$$

The “useful moment of the section” value is defined as :

$$M_{ut} = M_{\max} - M_{\min} = P^* [d(1 - \beta) + e_0 + e_1].$$

In figure 8 we observed before that the intervention of an external moment shifts the center of pressure upwards (positive moments) of a quantity  $\delta = M/P^*$  in respect of the resulting cable. If, from limit points  $E_0$  and  $E_1$  we move another two points downwards  $B_0$  and  $B_1$  at distances of respectively  $\delta_0 = M_{\min}/\beta P^*$  and  $\delta_1 = M_{\max}/P^*$  we can state that the resulting cable will be contained between these two points. By repeating the construction, section by section, an area (or cable zone) can be singled out, within which the resulting cable along the girder must be contained

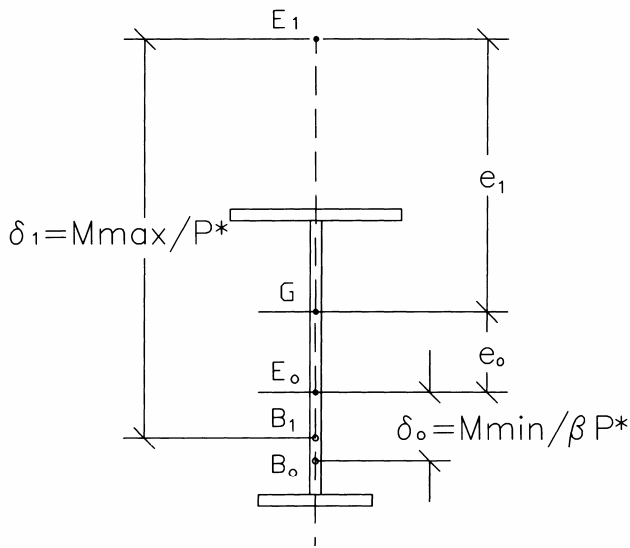

Figure 8. Resulting cable excursion.

In the following figures, several types of cable zone are shown for different types of girder.

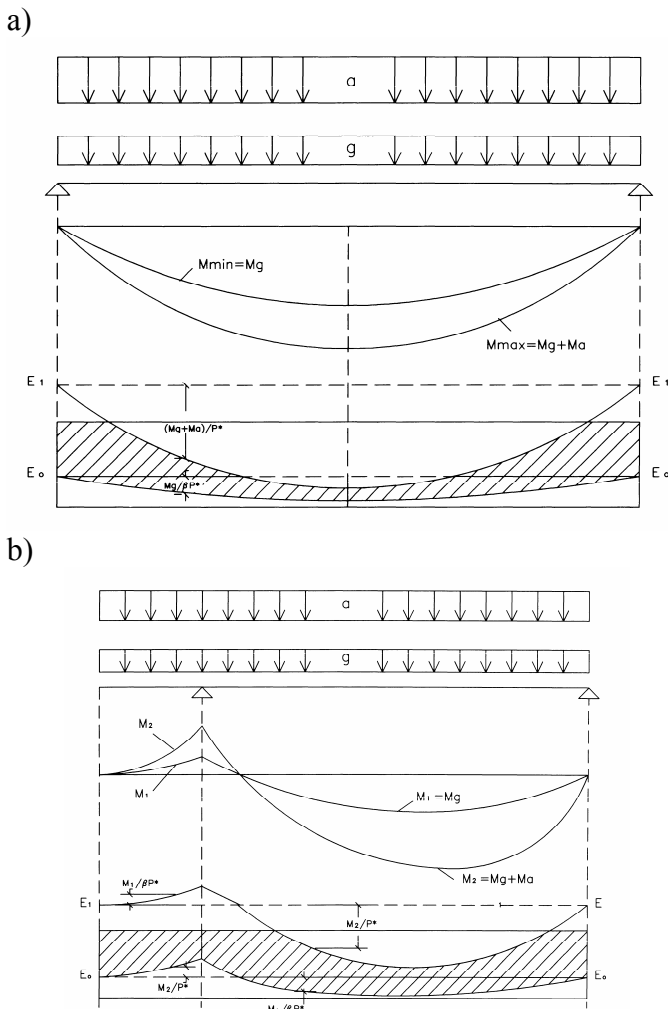

Figure 9. Cable zone.

### 2.2.2 Shear.

For a prestressed steel beam and generic section S, figure 10, we have:

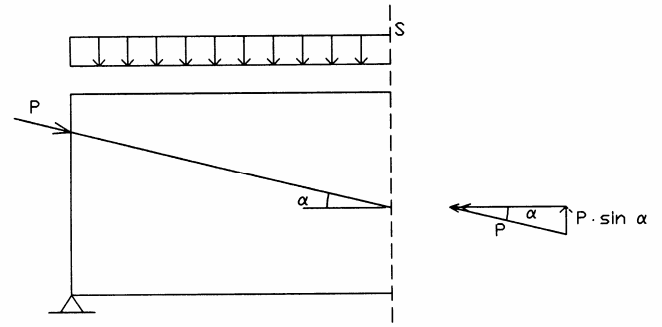

Figure 10. Shear

$$V_r = V - P \sin \alpha ;$$

or rather:

$$\begin{cases} V_r^0 = V^0 - \gamma_p \beta P \sin \alpha & \text{at transfer} \\ V_r^1 = V^1 - \gamma_p P \sin \alpha & \text{at service} \end{cases}$$

$\tau_{\max} = \frac{V_r}{t \cdot h}$ ; where t and h are respectively the thickness and the height of the web and thus:

$$\tau_{\max} \leq \frac{f_d}{\sqrt{3}} \text{ for pure shearing}$$

$$\sigma_{id} = \sqrt{\sigma^2 + 3\tau^2} \leq f_d \text{ for bending and shearing.}$$

### 2.3 The system of equivalent loads for prestressing.

The effect of prestressing on a steel girder may be analyzed by the introduction of a system of external loads (equivalent loads) which produce a series of stresses and deformations on the girder which are equivalent to its prestressing. Such stresses taken together with those produced by agent loads (dead and imposed) will give the overall state of stress to which the girder is subjected to. This must be compatible with the resistance and stability characteristics of the girder itself. A typical example of equivalent loads is shown in figure 11.

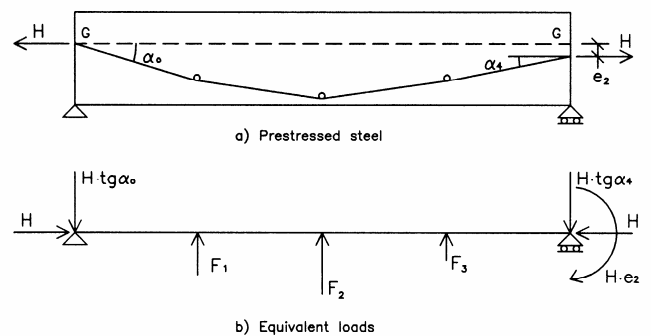

Figure 11. Equivalent loads.

## 2.4 The continuous prestressed steel girder.

The continuous girder is the simplest of the hyperstatic type structural typologies and its use is becoming ever more widespread in large structures. This presents advantages and disadvantages compared to a simply supported beam, for example, some advantages are lower flexure stresses, greater rigidity, less anchorage etc. Amongst the disadvantages are sensitivity to support failure, stress fluctuations, greater tension loss etc.

From a structural point of view, the main difference between simply supported beams and continuous beams is that, even without the presence of dead and imposed loads, the latter's prestressing means that side reactions may be generated (not always, as we shall see) which affect the state of stress. We consider a simply supported prestressed girder, figure 12a, without external loads (and neglecting its own weight), the resulting cable represents the "successive resulting polygon" to which we give the name "*line of pressures*". This line of pressures, whilst it coincides with the resulting cable in simply supported beams, in continuous beams is generally different.

In simply supported beam, prestressing gives place to a "*principal moment*"  $M_1 = P \cdot e$ , figure 12b, which upwardly deflects the beam itself, thereby causing a displacement equal to  $\delta_c$ , figure 12c. If we attach a sliding bearing to the beam in C (continuous beam) so as to cancel out displacement  $\delta_c$ , this constraint will have to react with force  $R_c$  which in turn will cause reactions  $R_A = R_B = P \cdot C/2$ , figure 12d. These reactions will cause a "*secondary moment*"  $M_2$ , figure 12e. The sum of the principal and secondary moments is termed the "*resulting moment*"  $M_3 = M_1 + M_2$ , figure 12f. In each section of a continuous beam, the effect of prestressing force  $P$  and the resulting moment  $M_3$  is equivalent to the product of force  $P$ , acting with deviation  $e_i$  in respect of the barycentre equal to  $e_i = M_3/P$ . The deviation line  $e_i$  along the longitudinal section of the beam is the "*line of pressures*" figure 12. The line of pressures deviates from the resulting cable by :

$$e - e_i = \frac{M_1}{P} - \frac{M_3}{P} = -\frac{M_2}{P}$$

therefore in an simply supported beam, being  $M_2 = 0$ , the line of pressures coincides with the resulting cable.

On the basis of this we can put forward a first general rule

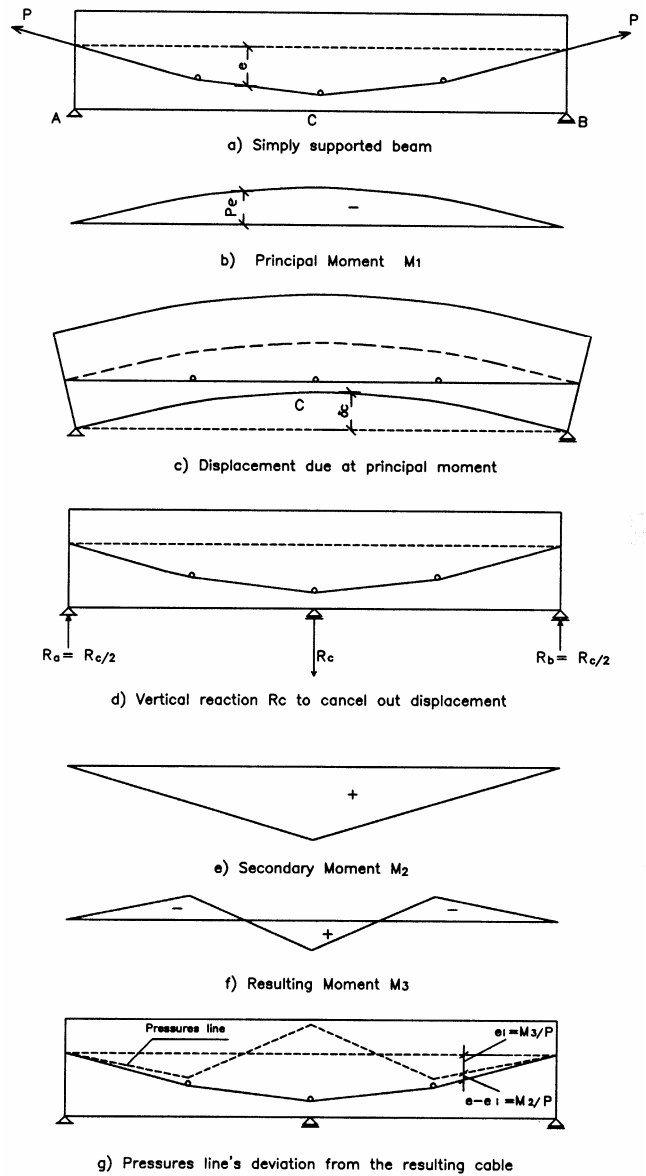

Figure 12. Continuous girder. Principle of function.

*1<sup>st</sup> Rule:* "In a continuous girder, the line of pressures is obtained from the resulting cable by lowering or raising opportunely, the profile of the intermediate supports, keeping the position of the extreme supports unchanged. This operation is called *linear transformation*."

The static regime of the continuous beam is characterized by the line of pressures. The equations derived for simply supported girders are also valid for continuous girders, provided that " $e$ " is substituted with " $e_i$ ", or rather:

$$\sigma_i^0 = -\frac{\gamma_p \beta P}{A} - \gamma_p \frac{\beta P e_i}{W_i} + \frac{M_{\min}}{W_i} \leq f_d$$

$$\left\{ \begin{array}{l} \sigma_s^1 = -\frac{\gamma_p P}{A} + \frac{\gamma_p P e_i}{W_s} - \frac{M_{\max}}{W_s} \leq f_d \\ \sigma_i^1 = -\frac{\gamma_p P}{A} - \frac{\gamma_p P \cdot e_i}{W_i} + \frac{M_{\max}}{W_i} \leq f_d \end{array} \right.$$

By analogous reasoning, the following second general rule is demonstrated:

2<sup>a</sup> Rule: “In a continuous P.S. girder, the cables that have terminal anchorages in the same position and keeping the same form, differing only by their deviation on the intermediate supports, have the same line of pressures. These are termed *equivalent cables*.”

In other terms, the equivalent cables give place to the same resulting moment  $M_3$ . This particular cable which coincides with the line of pressures which is verified by  $M_2 = 0$  and consequently  $R_{ip} = 0$ , is termed the “*concording cable*”. One final general rule may be made on the observation of the form of the diagram of moments and of that of the line of pressures.

3<sup>a</sup> Rule: “In a continuous P.S. girder, the diagram of moments in any system of forces (including the moments applied to the extremities) is the plot of the *concording cable*”.

## 2.5 Prestressed composite steel-concrete girders.

### 2.5.1 Introduction.

The system of prestressing is particularly advantageous for composite steel-concrete sections since the positive characteristics of both materials may be better exploited. Compared to the traditional treatment of not prestressed composite sections, the introduction of prestressing as a system of equivalent loads, has no particular novelty to offer in relation to what has already been described in the preceding paragraphs, apart from the fact of having to bear in mind that concrete, being subject to so-called “slow phenomena”, like viscosity and shrinkage, brings about a variation of the tension state as a function of time. Some typical prestressed composite sections are shown in figure 13, where we can notice, unlike steel sections, the symmetry of the profiles.

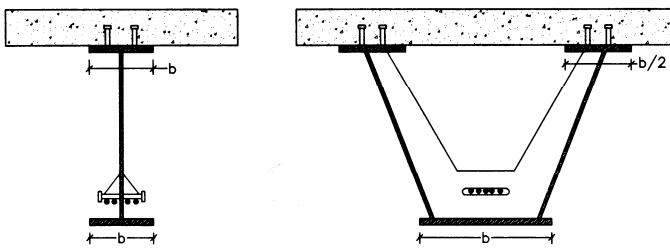

Figure13. Typical sections.

### 2.5.2 Calculation criteria.

The calculation of tensions, in reference to simply supported beams, is carried out by using the “homogenized section method”. The effect of viscosity of concrete with regard to the stresses and deformations produced by permanent loads is evaluated through the introduction of an imaginary elastic modulus. The effect of shrinkage is determined by an approximate method on the basis of values of strain at infinite time. The effect of thermal differen-

tial variations is evaluated on the basis of the value of the corresponding unitary deformation with criteria analogous to the case of shrinkage.

#### 2.5.2.1 Bending.

In reference to figure 14, we have:

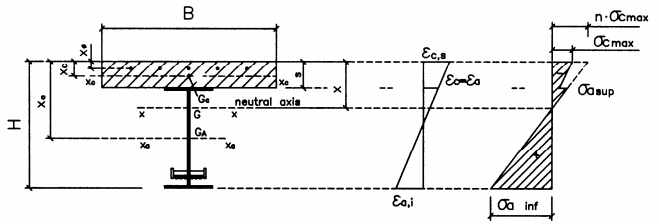

Figure 14. Prestressed composite girder.

$$A = A_a + A_\phi + \frac{A_c}{n}; \quad \text{dove: } n = \frac{E_s}{E_c}$$

There is nothing to say about the at transfer stage in regard to simple sections in P.C.. At service, we will have to verify :

$$\sigma_{c_{max}} = \frac{1}{n} \cdot \frac{M}{I} x < f_{cd}^*$$

$$\sigma_{a_{sup}}^1 = \sigma_{a_{sup}}^0 + \frac{M}{I} (x - h_c) \leq f_d$$

$$\sigma_{a_{inf}}^1 = \sigma_{a_{inf}}^0 + \frac{M}{I} (H - x) \leq f_d$$

#### 2.5.2.2 Shear

Resistance to shear action is only for steel girders, therefore we will have :

$$\tau = \frac{V}{t \cdot h} < \tau_{lim} = \frac{f_d}{\sqrt{3}} \text{ for pure shearing;}$$

$$\sigma_{id} = \sqrt{\sigma^2 + 3 \cdot \tau^2} \leq f_d \text{ for bending and shearing.}$$

## 2 CONCLUSIONS

Scarce knowledge of calculation methods and their potential represents, in our opinion, the main obstacle in widespread use of prestressed steel structures. This paper has pointed towards some calculation methods for P.S. structures in reference to girders, demonstrating their simplicity and possible applications.

## 3 BIBLIOGRAPHY.

Nunziata, Vincenzo 1999. *Strutture in acciaio precompresso*. Palermo: Dario Flaccovio, Editore.